

Overview

The Flexible Advantage **ST**arter base systems for the HP 9000 rp7420 Server allow for faster configurations and lower prices due to the semi configured base system bundles.

HP 9000 rp7420 Server FAST bundles

Product Number (Includes base chassis and power supplies)	Number of dual core PA-8900/8800 processor modules (processors)	Number of Cell Boards	Number of Core I/O
AB205A	2 (4)	1	1
AB206A	4 (8)	1	1
AB207A	6 (12)	2	2
AB208A	8 (16)	2	2

HP 9000 rp7420 Server System Overview-Front View

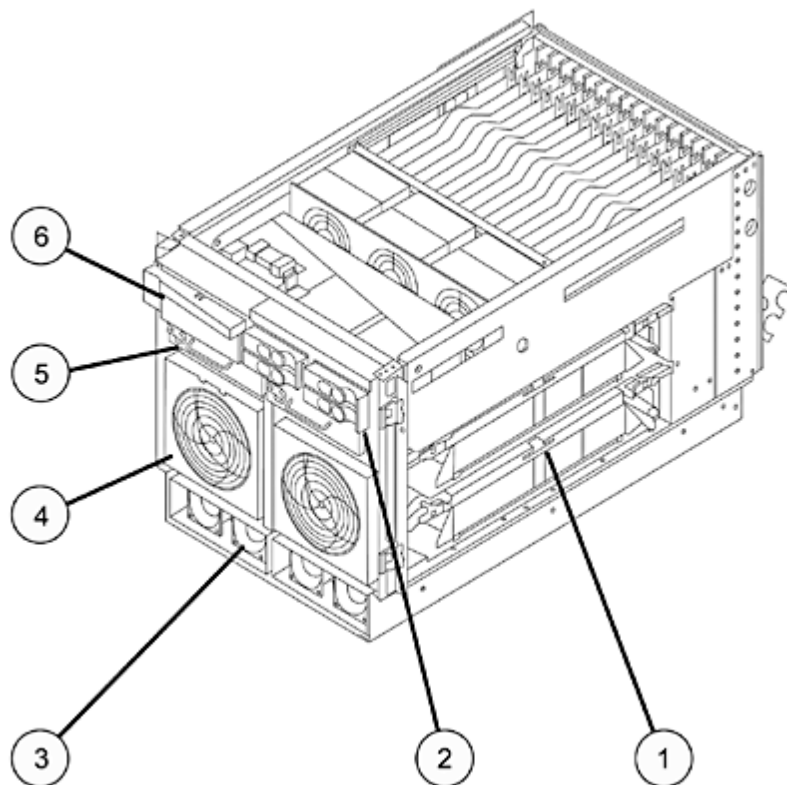

1. Cell Boards (2)
2. Hot-plug Disks (4)
3. 2N Redundant Hot-swap System Power (2)
4. N+1 Redundant Hot-swap Fans (2)
5. 2 Independent PCI Power Supplies
6. Removable Media DVD or DAT

Overview

HP 9000 rp7420 Server System Overview-Rear View

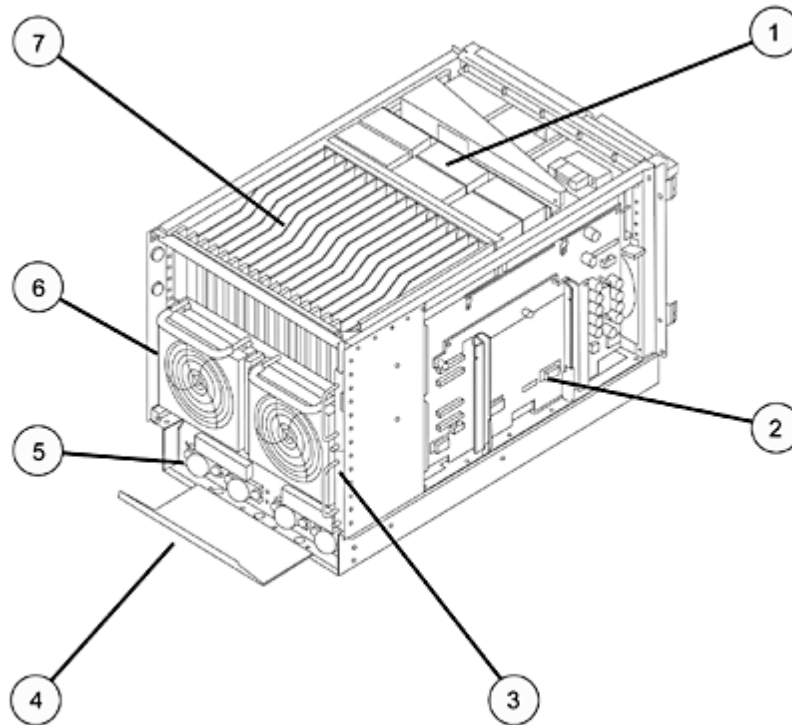

- 1. N+1 PCI Coding Fans
- 2. System Backplane (right side)
- 3. Core I/O
- 4. Power Cord Retention Bracket
- 5. Dual-grid 2N Redundant Power Inputs
- 6. Hot-swap Redundant Fans
- 7. 15 Hot-plug PCI-X Slots

Standard Features

Minimum System

- One processor core per dual core PA 8900/PA 8800 processors
- One Processor/Memory Cell Board
- 2-GB Memory (1 quad)
- One Core I/O board
- Two Hot-swap power supplies, providing 2N+1 protection
- Two Power cords
- Hot-plug 33/66/133-MHz×64-bit PCI-X slots-with adaptive signaling technology

Maximum Server Capacities

- Eight dual core PA-8900/8800 processor modules (16 processors)
- Two Processor/Memory Cell Boards
- 128-GB Memory (8 quads)
- Two Core I/O board sets
- Two Hot-swap power supplies, providing 2N protection
- Four power cords, providing 2N power and dual grid support
- Four internal hot-plug LVD SCSI disks
- 1 removable media drive, DVD or DAT
- 14 PCI expansion cards

Standard System Features

- 64 bit HP UX 11i v1 & 11iv2 operating system
- External Ultra160 LVD SCSI channel
- Four Internal SCSI controllers
- 10/100/1000Base-T LAN (with auto speed sensing)
- Management Processor technology with Integrated Web Console and LAN console
- RS-232 local and remote (modem) console and UPS ports
- 10/100Base-T LAN port for LAN console and web console
- Rackmountable into HP 19-inch cabinets (factory or field integration)
- Rackmountable into some 3rd party cabinets
- Pedestal configuration
- One or Two hardware partitions (nPartitions)
- Factory integration of Processors, memory, disk drives, removable media drives, and I/O cards
- HP site planning and installation
- One-year warranty with next business day on-site service response
- Owner's Guide and General Usage media set

Standard Features

High Availability

- N+1 Hot-swap cooling
- Redundant and hot-swap power supplies
- Hot-plug disks
- 2N power inputs (redundant line cords/dual power grid support)
- On-line memory page deallocation
- ECC protected SyncDRAM memory
- Full parity protection of data and address buses
- On-chip processor cache with ECC protection
- Memory "chip spare", "chip kill" like
- Dynamic Processor resilience and deallocation (processor deallocation on failure)
- CPU deallocation on failure
- On-line addition and replacement of PCI I/O cards
- UPS power management
- Three independent Ultra160 buses to internal disks for mirroring across disks and controllers
- Journal file system
- Auto reboot
- On-line diagnostics and system health monitor

Security

- Separate console LAN port for system management
- Password protection on console port
- Disablement of remote console ports

Internet Server Functions

- Internet server (inetd)
- Domain name server
- Routing (OSPF, BIND, RIP, EGP, HELLO, gateD)
- Network Time Protocol

Client Configuration Services

- Automatic configuration for printers, PCs, workstations, and X terminals (DHCP, Bootp, tftp, rbootp)

Optional Web Services

- Netscape Communication Server
- Netscape Navigator

Email

- Mail, MailX, ELM
- Sendmail, MIME, SMTP, ESMTMP

Remote Access Services

- Telnet, ftp, anonymous ftp server

Configuration

Configuration

The HP 9000 rp7420 Server is a symmetrical multiprocessing (SMP) server supporting up to 8 high performance dual core PA 8900 (1.1 GHz or 1.0 GHz) or PA 8800 (1.0 GHz or 900 MHz) processor modules. A dual core processor module supports two processors resulting in a 16-processor core server. It also supports the sx1000 chip set. The rp7420 Server can be configured as a single SMP server or divided into two smaller, hardware partitioned (nPars), logical servers.

Cell Boards

A minimum of one and a maximum of two cells can be ordered in an HP 9000 rp7420 Server. Each cell can be purchased with up to four active dual core PA 8900/PA 8800 processor modules (8 processors), or in combination with Instant Capacity processors. Four processor speeds are supported; 1.1 GHz and 1.0 GHz (using PA 8900) or 1.0 GHz and 900 MHz (using PA 8800). The ability to mix processor speeds within a chassis is supported (but processors within a cell or partition must be of the same speed). PA 8800 and PA 8900 may be mixed within the same chassis provided they are placed in different hardware partitions. PA 8800/PA 8900 and PA 8700+ processors may not be mixed in the same server. The HP 9000 rp7420 (8 processor module slots) and HP 9000 rp8420 (16 processor module slots) servers share the same cell board. A processor module slot contains 1 dual core processor module (2 processors). The HP 9000 rp7420 Server cell board can be carried forward to the HP Integrity rx7620 and supported Itanium processors in that chassis. The HP 9000 rp7410 cell board (A6096A) CANNOT be carried forward to the HP 9000 rp7420 Server and must be replaced (although previous HP 9000 rp7410 memory can be carried forward). When replacing previous HP 9000 rp7410 cell boards in an upgrade situation, cell board and PA 8700/8700+ return credits may be used.

Cell Details

- 4 processor module slots (supporting up to 8 processors)
- 16 Memory DIMM slots
- Cell Controller Chip-sx1000
- DC-DC Power converters

Cell Board Configuration Rules

- Cell boards are ordered individually
- Minimum: 1 cell board
- Maximum: 2 cell boards
- Cell slot 1 must be loaded first

Dual core PA 8900 processor module details

- 1.1 GHz or 1.0 GHz frequencies
- Level 2 Cache: 64 MB
- Level 1 Cache: 3 MB (1.5 MB integrated cache per core)
- 44 bit physical addressing
- 4-processor set associative cache
- Single bit cache error correction
- 4-processor superscalar
- 56 instruction reorder buffer
- Full PA RISC 2.0 binary compatibility

Configuration

Dual core PA-8800 processor module details

- 1.0-GHz or 900 MHz frequencies
- Level 2 Cache: 32 MB
- Level 1 Cache: 3 MB (1.5-MB integrated cache per core)
- 44-bit physical addressing
- 4-processor set associative cache
- Single bit cache error correction
- 4-processor superscalar
- 56 instruction reorder buffer
- Full PA RISC 2.0 binary compatibility

Processor Configuration Rules

- Processors can be ordered individually (2 processors) or upgraded individually.
- There must be at least one active core (non iCAP) processor on each cell board.
- On each cell board, processors must be installed in the following sequence 0, 2, 1, 3

Memory Configuration

The memory DIMMs used in the HP 9000 rp7420 Server are sold in quads and are custom designed by HP. Each DIMM contains 36×4 SDRAM memory chips qualified to run at 125 MHz, with full ECC protection. DIMM sizes of 512 MB, 1 GB, 2 GB, and 4 GB are supported. HP 9000 rp7410 memory modules can be carried forward to the HP 9000 rp7420 Server. Each HP 9000 rp7420 Server cell board supports up to 16 DIMMs with 16 GB/s of peak memory bandwidth. The 16 GB memory modules (4×4GB DIMMs) cannot be mixed with other memory DIMM sizes. When purchased from the factory, any given partition can ordered with 4 GB DIMMs or non stacked DIMMs (512 MB, 1 GB or 2 GB), but not both. When field integrated, cell boards can contain 4 GB DIMMs or non stacked DIMMs (512 MB, 1 GB or 2 GB), but not both.

The HP 9000 rp7420 and HP 9000 rp8420 servers share the same 2 GB, 4 GB, 8 GB, and 16 GB memory products.

HP 9000 rp7420 Server Memory DIMMs

Quad Size (product)	rp7420 Product Number	rp7410 Product Numbers that are supported	HP 9000 rp7420 Server Maximum Capacity Using 1 DIMM Size	DIMM Size
2 GB	AB307A	A6097A	16 GB	512 MB
4 GB	AB308A	A6098A	32 GB	1024 MB
8 GB	AB309A	A6100A	64 GB	2048 MB
16GB	AB322A	-	128 GB	4096 MB

Memory Loading Rules

- Memory must be installed in quads (4 DIMMs of equal size)
- Memory is available in four densities: 2 GB (4×512MB), 4 GB (4×1024MB), 8 GB (4×2048MB), and 16 GB (4 x 4096MB)
- Minimum memory is 2 GB per cell
- Maximum memory per system is 128 GB-using eight 16 GB quads.
- On each cell board, Memory Quads must be installed in the following order: 1st (0A, 0B, 1A, 1B), 2nd (2A, 2B, 3A, 3B), 3rd (4A, 4B, 5A, 5B), 4th (6A, 6B, 7A, 7B)

Configuration

Performance Tuning Guidelines

- A cell should be configured with a multiple of 8 DIMMs. It takes 8 DIMMs to populate both buses. Populating only one of the two memory buses on a cell board will deliver only half the peak memory bandwidth.
- Load memory equally across the available cell boards.
- If growth is planned for the system, then plan on configuring high density 4GB, 8-GB, or 16-GB modules to minimize future memory slot constraints.

Memory Latencies

There are two types of memory latencies within the HP 9000 rp7420 Server:

1. Memory latency **within** the cell refers to the case where an application either runs on a partition that consists of a single cell or uses cell local memory.
2. Memory latency **between** cells refers to the case where the partition consists of two cells and cell interleaved memory is used. In this case 50% of the addresses are to memory on the same cell as the requesting processor, and the other 50% of the addresses are to memory of the other cell.

The HP 9000 rp7420 Server average memory latency depends on the number of processors in the partition. Assuming that memory accesses are equally distributed across all cell boards and memory controllers within the partition, the average idle memory latency (load-to-use) is as show below:

Number of processor modules	Average Memory Latency
4-dual core processor modules (single cell)	~241 ns
8-dual core processor modules (two cell)	~292 ns

I/O Architecture

Components within the I/O subsystem are the I/O controllers, internal peripheral bay, and multifunction Core I/O. The figure below shows the basic block diagram of the I/O subsystem. The HP 9000 rp7420 Server I/O architecture utilizes industry standard PCI buses in a unique design for maximum performance, scalability and reliability.

The HP Integrity rp7420 Server contains two master I/O controller chips located on the PCI-X backplane. Each I/O controller contains 16 high-performance, 12-bit-wide links; these links connect to 18 slave I/O controller chips supporting the PCI card slots and core I/O. In the HP 9000 rp7420 Server, two links, one from each master controller, are routed through the system backplane and are dedicated to core I/O. The remaining thirty links are divided among the sixteen I/O card slots. This one card per link architecture leads to greater I/O performance and higher availability. Each controller chip is also directly linked to a host cell board. This means that both cell boards must be purchased in order to access all 15 available I/O card slots. (With only one cell board, access to seven expansion slots is enabled.)

The HP 9000 rp7420 Server can be purchased with either one or two core I/O board sets. Each Core I/O product contains two boards, a MP/SCSI and a LAN/SCSI card. The core I/O boards provide console, Ultra160 SCSI, Gigabit LAN, serial, and management processor functionality. If you opt for the second core I/O board set, it can be used to enable dual hard partitioning (nPars) in the HP 9000 rp7420 Server and to provide access to a second set of disk drives.

The LAN/SCSI card provided with each Core I/O product occupies one of the sixteen PCI slots. Since there must always be at least one Core I/O board set, the HP 9000 rp7420 Server has fifteen available PCI slots for expansion cards. If the second Core I/O product (board set) is purchased, there are fourteen remaining slots available for expansion cards.

The internal peripheral bay supports up to four low-profile disks and one removable-media device. The internal disks are electrically divided into two pairs. SCSI controller chips located on each core I/O board set supports each pair of internal disks. This means that you must have both board sets in order to access both halves of the peripheral bay. This also means that I/O paths are not shared, and disks are electrically isolated, providing for optimal isolation between partitions.

Configuration

PCI Backplane

Fourteen of sixteen I/O card slots are supported by dual high-performance links. Each link is capable of providing 530 MB/s of bandwidth. This means that most HP 9000 rp7420 Server I/O slots are capable of sustained 1.06 GB/s. Aggregate I/O slot bandwidth is 15.9 GB/s. In addition, because each I/O slot has a dedicated bus, any slot can be "hot-plugged" or serviced without affecting other slots. The hot-plug operation is very easy, and can be done with minimal training and effort.

The HP 9000 rp7420 Server supports a number of PCI and PCI-X HBA (I/O) cards for I/O expansion (see Table 2.7.5). Note that the PCI-X backplane is backward compatible with the older PCI backplane and can support many PCI HBA (I/O) cards.

When HP 9000 rp7410 servers are upgraded to HP 9000 rp7420 servers using the chassis upgrade kit A9785A, the older and slower PCI backplanes in the HP 9000 rp7410 server are upgraded to the newer and faster PCI-X backplanes of the HP 9000 rp7420 Server.

Supported I/O Cards (HBAs)

I/O Card	Product Number	First HP UX Release / Boot Support	Connector Type(s)	Hot Plug / Factory Integration	Max Cards / Max Ports	Special Notes
Mass Storage Host Bus Adapters						
PCI 1 port 2x Fibre Channel	A5158A	11.00 / No	Duplex SC	Yes / Yes	15 / 15	
PCI 2 Gb Fibre Channel	A6795A	11.00 / Yes	LC	Yes / Yes	15 / 15	
PCI 1-port 4-Gb Fibre Channel	AB387A	11i/Yes		Yes/Yes	15/15	
PCI 1 channel U160 SCSI	A6828A	11.00 / Yes	VHDCI	Yes / Yes	15 / 15	
PCI 2 channel U160 SCSI	A6829A	11.00 / Yes	VHDCI	Yes / Yes	15 / 30	
PCI 2 channel Ultra320 SCSI	A7173A	11i / Yes	VHDCI	Yes / Yes	15 / 30	
PCI 2 channel PCI 2-Gb/s Fibre Channel	A6826A	11.00 / No	LC (SFF)	Yes / Yes	15 / 30	
PCI 1 port Ultra2 SCSI	A5149A	11i / Yes	VHDCI	Yes / Yes	15 / 15	
PCI 2 port Ultra2 SCSI	A5150A	11.00 / No	VHDCI	Yes / Yes	15 / 15	
PCI-X 2 channel Smart Array 6402 U320	A9890A	11i / Yes	VHDCI	Yes / Yes	15 / 30	
PCI-X 2 channel SmartArray 6404	A9891A	11i / Yes	VHDCI	Yes / Yes	15 / 30	
PCI-X 2 Port 4X Infiniband HCA (HPC)	AB286A	11i v2 / Yes	VHDCI	Yes / Yes	8 / 16	
PCI-X 2-port 4X Fabric (HA & DB) Adpt	AB345A	11i v2	4x Infiniband Copper	Yes / No	15 / 30	
Local Area Network Interface Cards						
PCI-X 1-port 10 Gb Ethernet Fiber Adapter	AB287A	11i v2 / No	Duplex LC	Yes / Yes	2 / 2	
PCI-X 4-port 1000Base-T Gigabit Adpt	AB545A	11i v2 / No	RJ-45	Yes / No	15 / 60	
PCI X 2 port 1000Base SX	A7011A	11i / Yes	Duplex SC	Yes / Yes	15 / 30	
PCI X 2 port 1000Base T	A7012A	11i / Yes	RJ-45	Yes / Yes	15 / 30	
PCI 1 port 1000Base SX	A6847A	11.00 / Yes	Duplex SC	Yes / Yes	15 / 15	
PCI 1 port 1000Base T	A6825A	11.00 / Yes	Duplex SC	Yes / Yes	15 / 15	
PCI 1 port 1000Base SX	A4926A	11.00 / No	Duplex SC	Yes / Yes	15 / 15	
PCI 1 port 10/100Base T	A5230A	11.00 / No	RJ-45	Yes / Yes	15 / 15	
PCI 1 port 1000Base T	A4929A	11.i / No	RJ-45	Yes / Yes	15 / 15	

Configuration

PCI 4 port 10/100Base T	A5506B	11.00 / No	RJ-45	Yes / Yes	15 / 60	
PCI 1 port 802.5 Token ring 4/16/100 Mb/s	A5783A	11.00 / No	RJ-45 and DB-9	Yes / Yes	15 / 15	
PCI 1 port Universal FDDI	A3739B	11.00 / No	FDDI SC	Yes / Yes	15 / 15	
Multi-Function Cards (Mass Storage / LAN)						
PCI 2 port 100Base T/ 2 port Ultra2 SCSI	A5838A	11.00 / Yes	VHDCI/RJ-45	Yes / Yes	15 / 60	
PCI-X 2Gb Fibre Channel / 1000Base-SX	A9782A	11i / Yes	LC (SFF) / LC GigE	Yes / Yes	15 / 30	
PCI-X 2Gb Fibre Channel / 1000Base-T	A9784A	11i / Yes	1 LC, 1 RJ-45	Yes / Yes	15 / 30	
PCI-X 2-port 2GbFC/ 2-port 1Gb Ethernet	AB465A	11iv2 / Yes	2 LC/2 RJ-45	Yes / Yes	15 / 60	
PCI-X 2-port 1000BT/2-port U320 SCSI	AB290A	11i/Yes	2 LC GigE/2 RJ-45	Yes/Yes	15/60	
Wide Area Network Interface Cards						
PCI 1 port ATM 155 Mb/s Multi Mode Fiber (MMF)	A5513A	11.00 / No	Duplex SC	Yes/Yes	15 / 15	
2 port Programmable Serial Interface (PSI) X.25 / Frame Relay / SDLC	J3525A	11.00 / No	RS-530, RS-232, V.35, RS-449 or X.21	Yes / Yes	15 / 30	
Additional Interface Cards						
PCI 8 port Terminal Multiplexer	A6748A	11.00 / No	LC Duplex	Yes / Yes	15 / 120	
PCI 64 port Terminal Multiplexer	A6749A	11.00 / No	RS-232 or RS-422	Yes / Yes	15 / 960	
PCI Hyperfabric2 Fiber Adapter	A6386A	11.00 / No	RS-232	Yes / Yes	4 / 4	

Integrated Multifunction I/O

The HP 9000 rp7420 Server chassis supports up to two core I/O boards (AB306A). Core I/O slots are located along the right rear vertical edge of the chassis. A minimum of one core I/O board set must be ordered with each system; the optional second core I/O board set can be used to enable hardware partitioning or to utilize the full capacity of the built in mass storage bays.

When upgrading HP Server rp7410s ordered before September 2003, these older servers will require a Core I/O board upgrade. These servers were ordered with Core I/O product A6096A, which is not supported in the rp7410 to rp7420 upgrade.

Each HP 9000 core I/O board set provides the following features:

Configuration

- **Management Processor:** The Management Processor (MP) is a dedicated processor that simplifies and extends system management, as well as, enhances serviceability. The MP feature set was designed to minimize/eliminate the need for the System Administrator to be physically at the system to perform tasks such as diagnostics, system management, or even hard resets.
Features:
 - System management over the Internet or Intranet
 - System console redirection
 - Console mirroring
 - System configuration for automatic restart
 - Viewing history log of system events
 - Viewing history log of console activity
 - Setting MP inactivity timeout thresholds
 - Remote system control
 - Remote power cycle (except for MP housekeeping power)
 - Viewing system status
 - Event notification to system console, e-mail, pager, and/or HP Response Centers
 - Automatic hardware protection of critical environmental problems
 - Access to management interface and console(s) on LAN failure (modem required)
 - Auto system restart
 - Remote resetting of hardware partitions
 - Forward progress indicator (Virtual front-panel)
 - Out-of-band Manageability and PDC firmware update
 - Configure manageability and console security
 - SSL (Secure Sockets Layer)
- **External LAN port:** 10/100/1000Base-T LAN port using an RJ-45 connector
- **External SCSI port:** Ultra3 LVD SCSI port for connections to mass storage or media
- **Access to internal peripheral bay:** The first core I/O card enables half of the HP 9000 rp8420 peripheral bay, which includes one removable media and two low profile disks. The second core I/O card enables the remaining internal peripherals, two disks and one removable media bays. Customers that require access to more than two internal disks and/or one removable media slot must purchase the second core I/O card and more than one cell board.

Core I/O Loading Rules

- Minimum of one Core I/O board set (primary) must be purchased with each HP 9000 rp7420 Server
- Load the Primary (1) MP/SCSI board into slot 1 and the LAN SCSI board into I/O cabinet 1 (slot 8).
- MP/SCSI slot 0 and I/O cabinet 0 corresponds to Cell Board slot 0. MP/SCSI slot 1 and I/O cabinet 1 corresponds to Cell Board slot 1.
- A cell board must be installed in slot 0 to enable use of Core I/O 0. Likewise, a cell board must be installed in slot 1 to enable use of Core I/O 1.
- Access to two Internal disk drives and 1 Removable Media bay is enabled with the installation of the 1st Core I/O board set (Primary).
- The optional second Core I/O board set (secondary) must be ordered to enable hardware partitioning
- The optional second Core I/O board set (secondary) must be ordered to enable access to the 3rd/4th internal disks.

Configuration

Internal Disk Drives

- HP 9000 rp7420 Server supports up to four internal low-profile hot-plug disk drives in four capacities.
- Supported by MirrorDisk/UX across disk drives, controllers, and Core I/O boards
- Must order the second Core I/O board set to support more than two internal disk drives

Internal Disk Drive Specifications

Product Number	rp7410 Product Numbers that are supported	Disk Capacity	Rotational speed	Average seek time (read/write)	Sustained Bandwidth
A9880A	A6831A	36 GB	15,000 RPM	3.6 msec (read); 3.9 msec (write)	75 MB/s
A9881A	A6725A	73 GB	15,000 RPM (A9881A) 10,000 RPM (A6725A)	3.6 msec (read); 3.9 msec (write) (A9881A) 4.7 msec (read); 5.2 msec (write) (A6725A)	75 MB/s (A9881A) 69 MB/s (A6725A)
A9882A	A7083A	146 GB	10,000 RPM	4.7 msec (read); 5.2 msec (write)	69 MB/s
AD050A	N/A	300 GB	10,000 RPM	4.7 msec (read); 5.2 msec (write)	69 MB/s
AD146A	N/A	36 GB	15,000 RPM	3.6 msec (read); 3.9 msec (write)	75 MB/s
AD209A	N/A	73 GB	10,000 RPM	4.7 msec (read); 5.2 msec (write)	69 MB/s
AD148A	N/A	146 GB	10,000 RPM	4.7 msec (read); 5.2 msec (write)	69 MB/s
AD149A	N/A	300 GB	10,000 RPM	4.7 msec (read); 5.2 msec (write)	69 MB/s

Internal Removable Media

- HP 9000 rp7420 Server contains one removable media bay, which will support either a DVD-ROM or DDS-4 DAT drive. Removable media drives are not hot-plug capable.
- DVD-ROM drive provides enhanced features while preserving backward read compatibility with CD-ROM. Data transfer rates of up to 6.75 MB/s are achieved with the DVD format; 4.8 MB/s can be achieved with the CD format.
- DDS-4 drive has a maximum storage capacity of 40 GB with a peak transfer rate of 21.6 GB/hour compressed.

Internal Removable Media Specifications

Product Number	Device	Capacity	Data transfer rate
A9879A	DVD-ROM drive	650 MB	6.75 MB/s
A9878A	DDS-4 tape drive	40 GB	21.6 GB/hour
AB351A	DVD+RW	650 MB	
AB351B	DVD+RW (RoHS)	650 MB	
AB400A	DAT	72 GB	

I/O Configuration Rules The following table summarizes previously mentioned configuration rules pertaining to usage of I/O slots and internal peripherals.

Configuration

	Minimum Requirement	
Configuration	Minimum Number of Cells	Minimum Number of Core I/Os
>7 I/O card slots or access to both I/O card bays	2	1
>2 internal disks or access to both pairs of disks	2	2
1 Internal Removable Media	1	1
2 Hard Partitions	2	2

AC/DC Power

DC Power Supplies

The HP 9000 rp7420 Server comes with two power supplies that provided dual grid (2N) protection. The hot-swap design allows for the replacement of a failed power supply without interrupting server operation. All four power cords must be utilized to fully enable power supply hot swap.

PCI Power Supplies: Each PCI power supply is dedicated to a single I/O bay. A PCI power supply failure will affect the nPar utilizing that PCI supply and the associated I/O bay. All other nPars will continue normal operation. PCI power supplies are not hot-swap capable.

AC Power

The HP 9000 rp7420 Server contains four C20 power receptacle ports located at the bottom rear bulkhead. A minimum of two power cords must be used to maintain normal operation of the HP 9000 rp7420 Server. A second set of two cords can be added to improve system availability by protecting, for example, against power grid failures, accidentally tripped circuit breakers, or a failed power supply. The HP 9000 rp7420 Server hardware is capable of receiving AC input from two different AC power sources. The objective is to maintain full equipment functionality when operating from power source A and power source B or A alone or B alone. This capability is called "fault-tolerant power compliance".

Although many HP Integrity rx7620 configurations can be sufficiently powered from a single 16-/20-amp branch circuit, the optimum configuration is to use one 16-amp (minimum) branch circuit per power cord. Due to the variety of 16/20 plugs used throughout the world, the HP 9000 rp7420 Server menu offers a choice of plug options.

AC Power Consumption

The HP 9000 rp7420 Server power consumption will vary greatly depending on the hardware configuration and the input line voltages supplied at customer sites. Because of the disparity of line voltages throughout the world it's best to represent power consumption in VA (Volt*Amperes). With power consumption being of high concern throughout the world, it's necessary to specify consumption in a couple of different ways.

Maximum Theoretical Power: or "Maximum Configuration" (Input power at the ac input expressed as Volt-Amps to take into account Power factor correction.)

The calculated sum of the maximum worst case power consumption for every subsystem in the server. This number will NEVER be exceeded by a functioning server for any combination of hardware and software under any conditions.

Marked Electrical Power: (Input power at the ac input expressed as Volt-Amps.)

The server Marked Electrical Power is the rating given on the chassis label and represents the input power required for facility ac power planning and wiring requirements. This number represents the expected maximum power consumption for the server based on the power rating of the bulk power supplies. This number can safely be used to size ac circuits and breakers for the system under all conditions.

Typical Maximum Power: or User Expected Maximum Power, "Typical Configuration" (Expressed as Volt-Amps.)

Configuration

The measured maximum worst case power consumption. This number represents the largest power consumption that HP engineers were able to produce for the server with any combination of hardware under laboratory conditions using aggressive software applications designed specifically to work the system at maximum load. This number can safely be used to compute thermal loads and power consumption for the system under all conditions.

Configuration

HP 9000 rp7420 Server Fully Loaded Configuration

- Eight dual core 1.1 GHz PA 8900 processor modules
- 128 GB of memory
- 14 PCI cards
- 2 cell boards
- 4 internal hard drives
- 1 DVD drive
- 2 core I/O board sets
- 2 bulk power supplies.
- Typical maximum power: 2,015 VA (1975 W) (10.1 A @ 200 VAC across two cords)
- Theoretical maximum power: 3,060 VA (2999 W) (15.3 A @ 200 VAC across two cords)
- Marked Electrical power for server: 2,640 VA (12A @ 220VAC)

HP 9000 rp7420 Server Average Configuration

- Four 1.1 GHz dual core PA 8900 processor modules
- 4 GB of memory
- 8 PCI cards
- 1 cell board
- 1 internal hard drives
- 0 DVD drive
- 1 core I/O board set
- 2 bulk power supplies.
- Typical power consumption: 995 VA (975 W) (4.9 A @ 200 VAC across two cords)

Power Distribution Units

60 amp Power Distribution Unit-

AF916A (NA/JPN) and AF917A (International) - supported in 10KG2 rack

E7683A (NA/JPN) and E7684A (International) - supported in Rack System E

Customers who prefer the fewest higher amperage connections from their ac line current source to the HP 9000 rp7420 Server can use the 60 amp power distribution unit (PDU). This PDU is sold separately and can be ordered with any HP server solution.

Each 60 amp PDU can support up to two HP 9000 rp7420 servers if the PDU is not mounted in the same rack. Up to three HP 9000 rp7420 servers can be supported if the PDU is mounted within the same rack.

Configuration Example for Using the 60 amp Power Distribution Unit

In this case there are two HP 9000 rp7420 Servers (average configurations drawing ~5 amps each) and two 60 amp PDUs configured with redundant power. The solid line cords represent the primary power connections needed for normal operation. In this example, cords from each server are plugged into a separate branch circuits. However, it is acceptable for each server to plug both grid A (A0 and A1) cords into one branch circuit and both grid B cords (B0 and B1) into a 2nd branch circuit. The remaining PDU outlets can be used to power other servers/components as long as specs per PDU rating is not exceeded.

Configuration

For redundant power inputs, the second set of cords (dotted line) is added. If the second PDU is plugged into a second grid this configuration provides protection against:

- Losing power from a single power grid
- Accidental tripping of one or two circuit breakers
- Accidental disconnect of a single PDU power cord
- Accidental disconnect of up to four (two from each system) system power cords

30 amp Power Distribution Unit-

252663-D74 (NA/JPN) and 252663-B33 (International) - supported with 10K G2 rack

E7681A (North America) and E7682A (International)- supported with Rack System E

A 30 amp Power Distribution Unit (PDU) is also supported with HP Integrity rx7620. Rack configurations consisting of peripherals and only one HP 9000 rp7420 Server will likely be best supported with the 30 amp PDU. This PDU is sold separately and can be ordered with any HP server solution.

Unlike the 60 amp PDU, each 30 amp PDU can only support one HP Integrity rx7620. The following configuration guidelines apply when using the 30 amp PDU:

- A0 and A1 or B0 and B1 cords should never be plugged into the same PDU.
- Use two 30 amp PDUs to achieve input power redundancy (plugging A0/A1 and B0/B1 into separate PDUs.)
- Ordering tools will not force the purchase of a second PDU for input power redundancy. A second PDU must be manually selected if redundant input power is desired.

Partitioning

A hardware partition corresponds roughly to a single, standalone system. Each HP 9000 rp7420 Server can be subdivided into two partitions, each containing one cell that has minimal shared resources with the other cell (partition). Cells are grouped into physical structures called cabinets or nodes. Special programmable hardware in the cells defines the boundaries of a partition in such a way that the isolation is enforced from the actions of other partitions. Each partition runs its own independent instance of the operating system. Applications cannot span partitions since each partition runs its own instance of the OS, essentially functioning as a stand-alone server. However, different partitions may be executing the same or different revisions of an operating system.

Each partition has its own independent processors, memory and I/O resources consisting of the resources of the cells that make up the partition. Resources may be removed from one partition and added to another without having to physically manipulate the hardware just by using commands that are part of the System Management interface. With a future release of HP-UX, using the related capabilities of dynamic reconfiguration (e.g. on-line addition, on-line removal), new resources may be added to a partition and failed modules may be removed and replaced while the partition continues in operation.

Partitioning the resources of the complex in this way makes it easy to run multiple application environments on the same physical system; you can allocate physical resources and tune the operating system running on each partition depending on the needs of the application (or the most important application) you intend to run on it. Alternatively, you can configure the HP 9000 rp7420 Server as a single partition, allowing all the resources to be focused on a single set of tasks, for example a large online transaction-processing application.

You can increase or reduce the processing power of a partition by adding or deleting cells (at this release, you must shut down the operating system running on the affected partition(s) before moving cells, and before configuration changes will take effect). Though HP UX 11i does include commands for some configuration tasks, HP recommends you use the Partition Manager (parmgr) to configure partitions.

The current release of HP 9000 rp7420 Server/HP UX 11i supports hardware partitioning. Hardware based partition configuration changes may require a reboot of the partition depending upon the

Configuration

configuration change. The reboot of the partition only affects the partition that is being reconfigured. The other partition defined in the chassis is not affected and will continue to execute without interruption. In a future HP UX release, dynamic hard partitions will be supported. Dynamic partitions imply that partition configuration changes do not require a reboot of the partition.

The HP 9000 rp7420 Server can be divided into two independent hardware partitions. In a partitioned configuration, system resources such as cell boards, I/O slots, core I/O, and disks, are evenly split between the two partitions (the removable media device is dedicated to partition 1). There is no flexibility to otherwise divide these components. For example, it is not possible to include 12 I/O slots in partition 0 and 4 I/O slots in partition 1; the split must be even.

The table below summarizes the resource split between hardware partitions.

	Cells (required)	I/O slots	Core I/O (required)	Disk/Media Bays
Partition 0	Cell 0	7	1	2/0
Partition 1	Cell 1	7	1	2/1

In addition to hard partitioning (nPars), HP 9000 rp7420 servers support virtual partitioning (vPars) to the single processor or processor level (expected release of support or vPars on HP 9000 rp7420 servers in second calendar quarter of 2004). With vPars, a user may support up to eight separate virtual partitions each with an instance of HP-UX 11i v1 within each hard partition. VPars provides many of the features of nPars but without the electrical isolation and support for hardware failures that nPars provides. See the Virtual Partitioning section of this Configuration Guide for more details.

Racking

The HP 9000 rp7420 Server was designed to provide industry leading performance density and availability when ordered in a racked configuration. At 10 EIA units (17.5 inches), four HP 9000 rp7420 servers can be mounted into a single HP two meter cabinet.

The HP 9000 rp7420 Server industrial design and packaging was designed to allow easy and quick access to all of the system's components. The most frequently handled devices, removable media and disks, are directly accessible at the system's front. By removing the front bezel, hot swap fans, hot swap power supplies, and PCI power supplies can be completely serviced. At the rear, core I/O and more hot swap fans are directly accessible. For access to all other components, the rack mounted HP 9000 rp7420 Server comes with rack sliders.

These rack sliders enables the HP 9000 rp7420 Server to be slid forward out of the HP cabinet for servicing of internal components such as fans, cell boards, and I/O cards, while the system is still running. The sliders also allows for servicing or replacement of any FRU (field replaceable unit) without removing the chassis from the cabinet. The HP 9000 rp7420 Server industrial design and slider strategy enables access and removal of any FRU within 15 minutes or less. This design feature minimizes the downtime associated with system upgrades in the rare event of a component failure. Also included with ever rack mounted HP 9000 rp7420 Server is a cable management arm (CMA) The CMA neatly secures data cables and prevents cables from becoming entangled while servicing of the system.

Ballasts for HP Rack System E cabinets (not required for new Universal 10K G2 rack)

Due to the weight of the HP 9000 rp7420 Server, ballast kits have been developed to add stability to HP cabinets while the system is being serviced. Every HP 9000 rp7420 Server shipped to customers will be shipped with a ballast kit. These ballasts were designed to easily attach to the rear anti tip foot that comes standard with every HP Rack System E cabinet. Use of the HP 9000 rp7420 Server ballast kit is mandatory and should be installed immediately. A common ballast kit is used for both the HP 9000 rp7420 Server, HP Integrity rx7620 and HP Server rp7410. Only one kit is needed for each cabinet containing one or more of these servers.

Configuration

Heavy Duty Stabilizing Kit for 10KG2 racks (not required for HP System E racks) A heavy duty stabilizing kit is required for the rack of the rx8640 server to add stability for the HP Universal 10K G2 rack. With this stabilizing kit, the ballast is no longer needed with the new HP Universal rack. Use of the Heavy Duty Stabilizing kit is mandatory and should be installed immediately.

Refer to the 10000 G2 Series Rack Best Practices Guide for information on rack deployment, stabilization and transportation. Go to <http://HP.com/go/rackandpower> for more information.

Third-Party Racking

HP Servers are designed to maximize performance density when installed into HP system cabinets. HP system cabinets maintain the high level of safety and reliability of HP Server solutions that customers have come to expect. Although HP strongly recommends racking servers in HP cabinets, it recognizes that some customer circumstances may prohibit this. For those customers, HP has developed a set of guidelines that when followed, enables server installations into third-party cabinets. It is extremely important that the guidelines be followed due to the wide variety of cabinets in the market place.

When field racking for the mid-range servers in any rack (10K G2, System E or 3rd party), the customer will have to order the appropriate service product (HP PN: HA124A1 Opt. 570 - HP Startup Field Racked Mid Server Service).

Upgrades

HP Server rp7410 Upgrades to HP 9000 rp7420 Server

The HP 9000 rp7405/rp7410 Servers were designed to be easily upgradeable to Intel Itanium 2 and PA-RISC processors. With the release of the Intel Itanium 2 Madison and the HP mx2 processors, HP 9000 rp7405/rp7410 Server customers can now upgrade their systems as desired.

So here are the components that a customer will need to order to do a board level upgrade to these new servers from an rp7405 or rp7410 server:

- **A chassis upgrade kit:** This product will contain new PCI-X (133 MHz) I/O backplanes (two logical backplanes, one physical backplane), a new front bezel, new firmware and various labels to apply to the server. Most old PCI I/O cards will run in the new PCI-X I/O backplane.
- HP 9000 rp7405/rp7410 to HP Integrity rx7620 upgrades-use product A9790A
- **New sx1000-based cell boards:** These cell boards contain four processor modules and are the same for the Itanium 2 Madison, HP mx2, and PA 8800/PA 8900 processors. You can install two Intel Itanium 2 Madison modules (four cores in four processor modules), or four mx2 modules (eight cores in four processor modules). You cannot intermix PA 8800/PA 8900, Intel Itanium 2 Madison, or mx2 modules on the same cell board. You cannot intermix PA 8800/PA 8900, Intel Itanium 2 Madison, or HP mx2 modules in the same server (with the exception that Intel Itanium 2 Madison and HP mx2 modules can be intermixed in the same server on differing cell boards and differing hard partitions). Memory previously installed on the replaced cell board will be just reinstalled on the new cell board.
 - HP Integrity mid-range server cell board-use product A6913A
 - When upgrading to HP mx2 modules and if ordering 1 processor module per cell board, you must order one cell board socket terminator (AB225A)
 - When upgrading to HP mx2 modules, you must buy one cell board baffle (A9792A) per cell board being upgraded
- **New processor modules:** HP sells two processors per module. These will replace two processors of the older modules.
 - Intel Itanium 2 dual-processor module, 1.3-GHz, 3-MB cache-use product A9765A
 - Intel Itanium 2 dual-processor module, 1.5-GHz, 6-MB cache-use product A6438A
 - HP mx2 dual-processor module, 1.1-GHz, 4-MB L3 cache, 32-MB L4 cache-use product A9767A
- **New core I/O cards:** In order to support the new PCI-X I/O backplanes, new core I/O cards have to be used.
 - rp7420/rx7620 core I/O card (A9918A) replaces old rp7405A/rp7410 core I/O card (A6793A)
- **Add in I/O cards:** A total of 33 I/O adapters were available for the rp7410 platform. The vast majority of these, 24, are compatible and can be used when upgrading from a rp7410 to a rp7420 platform. The following I/O cards are NOT compatible when upgrading from a rp7410 to a rp7420 platform.

Mass Storage	LAN	WAN	Other
A5856A	A5483A	Z7340A	A6092A
A7143A		J3526A	A5486A
A4800A			
A5159A			

Upgrades

- **Return credits:** If the customer returns his old cell boards, processor modules or core I/O boards, they can get a return credit:
Processors (**NOTE:** These are single processor credits, not dual processor module credits. This means that two PA 8700 return credits should be ordered for each new dual processor module purchased.):
 - rp7405/rp7410 650 MHz module-no return credit allowed
 - rp7410 750 MHz single processor return credit-use product A6444AN option 001
 - rp7410 875 MHz single processor return credit-use product A6435AN option 001Cell Boards:
 - cell board return credit-use product A6094AN option 001Core I/O cards:
 - rp7405/rp7410 core I/O card (A6793A) return credit-use A6793AN option 001
- **Software:**
 - For the HP Integrity servers, the operating system needs to be upgraded to HP UX 11i version 2

Technical Specifications

Server model number rp7420

Server product number Base A7025A
 Number of processors 1-8 (16)
 (# of core)

Supported Processors	PA-8900 Dual core 1.1 GHz Processors	L1 Cache (1.5-MB/core)	3 MB
		L2 Cache	64 MB
	PA-8900 Dual core 1.0 GHz Processors	L1 Cache (1.5-MB/core)	3 MB
		L2 Cache	64 MB
	PA-8800 Dual core 1.0 GHz Processors	L1 Cache (1.5-MB/core)	3 MB
		L2 Cache	32 MB
	PA-8800 Dual core 900 MHz Processors	L1 Cache (1.5-MB/core)	3 MB
		L2 Cache	32 MB

Memory	Memory slots	32 (16 per cell board)
	Minimum memory (Quad: 2 GB 4 DIMMs)	
	Maximum memory capacity	128 GB (64 GB per cell board)

Internal Disks	Maximum disk mechanisms	4
	Maximum disk capacity	1.2 TB
	Internal removable media DVD ROM	1 slot
	DDS 4 DAT	40 GB

Internal Removable Media 1 slot	DVD ROM	
	DDS 4 DAT (optional)	40-GB

Core I/O	Ultra3 SCSI-LVD	Yes
	10/100/1000Base-T (RJ-45 connector)	Yes
	RS-232 serial ports (one console and one UPS)	2
	10/100Base-T port (Web and LAN console conn.)	Yes

Technical Specifications

I/O Buses and Slots	Total Hot-plug PCI-X Slots	15
		(133 MHz×64 bits)
	14 Dual channel slots (1060 MB/s each)	
	2 Single channel (530 MB/s each)	

Maximum I/O Cards See supported I/O table	Mass Storage	8-15
	LAN	15
	WAN	15
	Multi-Function (Mass Storage / LAN)	15
	Additional Interface Cards	4-15

Electrical Characteristics	AC Input power	200-240V 50/60 Hz
	Hotswap Power supplies	2 total, included with base
	Redundant AC power	2 required, 4 cords for 2N inputs
	Typical maximum power dissipation for maximum processor, memory, disk, I/O configurations	2015 VA (1975 W) 10.08A @200VAC
	Marked Electrical per server	2640 VA (12A @ 220VAC)
	Marked Electrical per line cord	1320 VA (6A @ 220VAC)
	Power factor at full load	0.98 (approximately)
	kW rating for UPS loading¹	3.0

NOTE 1: Represents theoretical maximum power/heat dissipation under worst case conditions, may increase with future upgrades.

Site Preparation	Site planning and installation included	Yes
	Depth (inches/mm)	30 in (762 mm)
	Width (inches/mm)	19 in (482 mm)
	Height (inches/mm/EIA) Racked	17.5 in (445 mm) 10 units
	Weight (lb/kg)	101.6 kg./224 lbs.

Technical Specifications

Environmental Characteristics	Acoustics (sound power) at 25°C	7.4 Bels LwA
	Acoustics (sound power) at 30°C	7.4 Bels LwA
	Acoustics (operator/bystander) at 24°C	58.4 dB LpA
	Operating Temperature (up to 5000 ft) ²	41° to 95° F (5° to 35° C)
	Non-operating Temperature	-40° to 158° F (-40° to 70° C)
	Maximum rate of temperature change	20°C/hour
	Operating relative humidity	15% to 80%, non-condensing, max. web bulb = 26°C
	Non-operating relative humidity	5% to 80%, non-condensing
	Operating altitude above sea level	To 3.0 km (10,000 feet)
Non-operating altitude above sea level	To 4.5 km (15,000 feet)	

NOTE 2: Maximum operating temperature range up to 1.524 km (5000 ft). For higher altitudes derate the max temperature by 1°C/350 meters (1000 ft) above 1.524 km (5000 ft).

Regulatory Compliance	Regulatory Model Number	RSVLA-0102
	Electromagnetic Interference	Complies with FCC Rules and Regulations, Part 15, as a Class A digital device. Manufacturer's Declaration to EN55022 Level A, VCCI Registered, Class 1, Korea RLL
	Safety	CSAus Certified, compliant with EN 60950

© Copyright 2006 Hewlett-Packard Development Company, L.P.

The information contained herein is subject to change without notice.

Intel and Itanium are registered trademarks or trademarks of Intel Corporation in the U.S. and/or other countries.

The only warranties for HP products and services are set forth in the express warranty statements accompanying such products and services. Nothing herein should be construed as constituting an additional warranty. HP shall not be liable for technical or editorial errors or omissions contained herein.