

## Overview

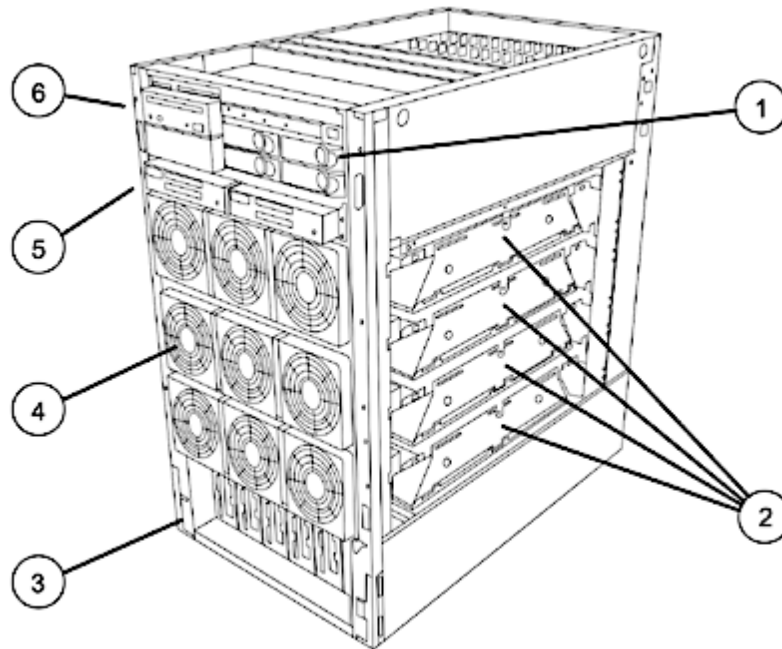

- |                             |                            |
|-----------------------------|----------------------------|
| 1. Hot-plug Disks           | 4. Redundant Hot-swap Fans |
| 2. Cell Boards              | 5. PCI Power Supplies      |
| 3. Redundant Hot-swap Power | 6. Removable Media DVD/DAT |

## Overview

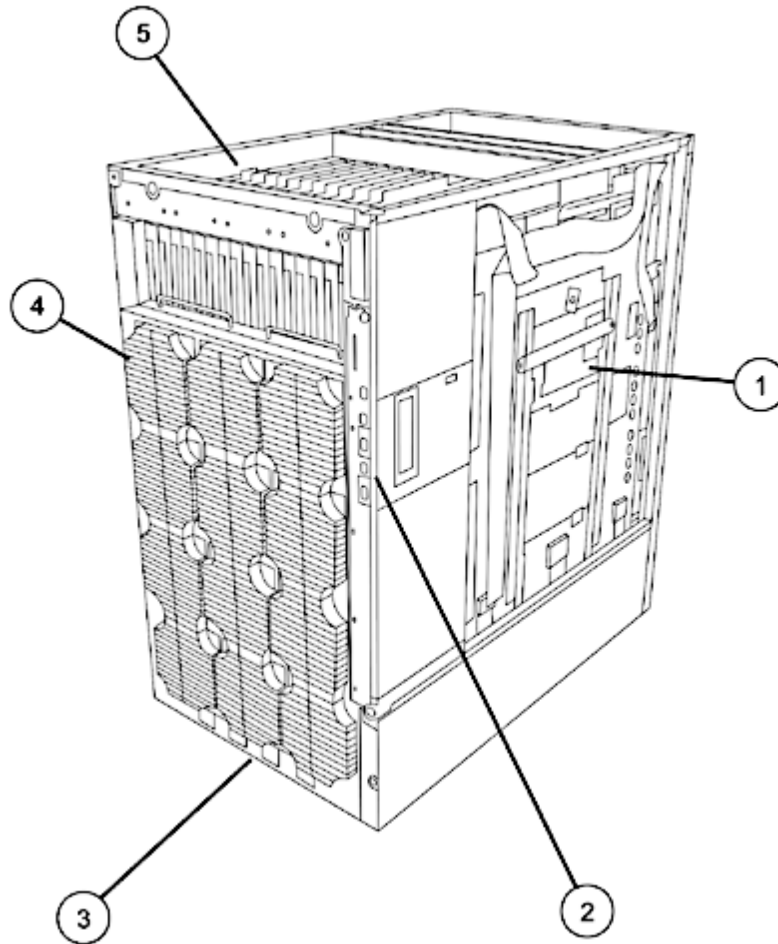

- 1. System Backplane
- 2. Core I/O
- 3. 2N Redundant Power Inputs

- 4. Hot-swap Redundant Fans
- 5. Hot-plug PCI Slots

## Standard Features

### Minimum System

- One processor core for dual core PA-8900 processors.
- One Processor/Memory Cell Board
- 2-GB Memory (1 quad)
- One Core I/O board
- Three Hot-swap power supplies, providing 2N+1 protection
- Two Power cords
- Hot-plug 33/66/133-MHz×64-bit PCI-X slots-with adaptive signaling technology

### Maximum Server Capacities

- Sixteen dual core PA-8900 (32 cores)
- Four Processor/Memory Cell Boards
- 256-GB Memory (16 quads)
- Two Core I/O boards
- Six Hot-swap power supplies, providing 2N+1 protection
- Four power cords, providing 2N power and dual grid support
- Four internal hot-plug LVD SCSI disks
- Two Removable media drives, DVD or DAT
- Sixteen PCI or PCI-X expansion cards

Max capacities when configured with the Server Expansion Unit (SEU)

- Four Core I/O boards
- Eight internal hot-plug LVD SCSI disks
- Four Removable media drives, DVD or DAT
- 32 PCI or PCI-X expansion cards

### Standard System Features

- 64 bit HP UX 11i v1, 11i v2 and 11i v3 operating system
- External Ultra3 LVD SCSI channel
- Four Internal Ultra SCSI channels, one channel to each internal disk
- 10/100/1000Base-T LAN (with auto speed sensing)
- Management Processor technology with Integrated Web Console and LAN console
- RS-232 local and remote (modem) console and UPS ports
- 10/100Base-T LAN port for LAN console and web console
- Rackmountable into HP 19-inch cabinets (factory or field integration)
- Rackmountable into some 3rd party cabinets
- Pedestal configuration
- One to two hardware partitions (nPartitions)
- One to four hardware partitions (nPartitions) when configured with the Server Expansion Unit
- Factory integration of processors, memory, disk drives, removable media drives, and I/O cards
- HP site planning and installation
- One-year warranty with same business day on-site service response
- Owner's Guide and General Usage media set

## Standard Features

### High Availability

- N+1 Hot-swap cooling
- Redundant and hot-swap power supplies
- Hot-plug disks
- 2N power inputs
- On-line memory page deallocation
- ECC protected SyncDRAM memory
- Full parity protection of data and address buses
- On-chip processor cache with ECC protection
- Memory "chip spare", "chip kill" like
- Dynamic Processor resilience and deallocation (processor deallocation on failure )
- Processor Module deallocation on failure
- On-line addition and replacement of PCI I/O cards
- UPS power management
- Four independent UltraSCSI buses to internal disks for mirroring across disks and controllers
- Journal file system
- Auto reboot
- On-line diagnostics and system health monitor

### Security

- Separate console LAN port for system management
- Password protection on console port
- Disablement of remote console ports

### Internet Server Functions

- Internet server (inetd)
- Domain name server
- Routing (OSPF, BIND, RIP, EGP, HELLO, gateD)
- Network Time Protocol

### Client Configuration Services

- Automatic configuration for printers, PCs, workstations, and X terminals (DHCP, Bootp, tftp, rbootp)

### Optional Web Services

- Netscape Communication Server
- Netscape Navigator

### Email

- Mail, MailX, ELM
- Sendmail, MIME, SMTP, ESMTMP

### Remote Access Services

- Telnet, ftp, anonymous ftp server

### Configuration

#### Configuration

The HP 9000 rp8420 Server is a symmetrical multiprocessing (SMP) server supporting up to 16 high performance dual core PA-8900 (1.1 GHz or 1.0 GHz) processor modules. A dual core processor module supports two cores resulting in a 32 core server. It also supports the new and improved sx1000 chip set. The rp8420 can be configured as a single SMP server or divided into up to four smaller, hardware partitioned (nPars), logical servers.

#### Cell Boards

A minimum of one and a maximum of four cells can be ordered in an HP 9000 rp8420 Server. Each cell can be purchased with up to four active dual core PA-8900 processor modules (eight cores), or in combination with Instant Capacity processors. Four processor speeds are supported; 1.1 GHz and 1.0 GHz (using PA-8900) or 1.0 GHz and 900 MHz (using PA 8800). The ability to mix PA 8800 or PA 8900 processor speeds within a chassis is supported (but processors within a cell or partition must be of the same speed). PA-8800 and PA-8900 may be mixed within the same chassis provided they are placed in different hardware partitions. PA-8800/PA-8900 and PA-8700+ processors may not be mixed in the same server. The HP 9000 rp8420 Server (16 processor module slots) and HP 9000 rp7420 (8 processor module slots) servers share the same cell board. A processor module slot contains 1 dual core processor module (two cores). The HP 9000 rp8420 Server cell board can be carried forward to the HP Integrity rx8620 and supported Itanium processors in that chassis. The HP 9000 rp8400 cell board (A6096A) **cannot** be carried forward to the HP 9000 rp8420 Server and must be replaced (although previous HP 9000 rp8400 memory can be carried forward). When replacing previous HP 9000 rp8400 cell boards in an upgrade situation, cell board and PA-8700/8700+ return credits may be used.

#### Cell Details

- 4 Processor module slots (supporting up to 8 cores)
- 16 Memory DIMM slots
- Cell Controller Chip – sx1000
- DC-DC Power converters

#### Cell Board Configuration Rules

- Cell boards are ordered individually
- Minimum: 1 cell board
- Maximum: 4 cell boards
- Cell slots 0 or 1 must be loaded first
- Recommended Cell board loading order: 0, 1, 2, 3

#### Dual core PA-8900 processor module details

- 1.1 GHz or 1.0 GHz frequencies
- Level 2 Cache: 64 MB
- Level 1 Cache: 3 MB (1.5 MB integrated cache per core)
- 44 bit physical addressing
- 4processor set associative cache
- Single bit cache error correction
- 4processor superscalar
- 56 instruction reorder buffer
- Full PA RISC 2.0 binary compatibility

#### Processor Configuration Rules

- Processors can be ordered individually (2 processors) or upgraded individually
- There must be at least one active processor core (non iCAP) on each cell board.
- On each cell board, processors must be installed in the following sequence 0, 2, 1, 3

## Configuration

**Memory Configuration** The memory DIMMs used in the HP 9000 rp8420 Server is sold in quads and is custom designed by HP. Each DIMM contains 36×4 SDRAM memory chips qualified to run at 125 MHz, with full ECC protection. DIMM sizes of 512 MB, 1 GB, 2 GB, and 4 GB are supported. HP 9000 rp8400 memory modules can be carried forward to the rp8420 server. Each HP 9000 rp8420 Server cell board supports up to 16 DIMM slots and 16 GB/s of peak memory bandwidth. The 16 GB memory modules (4×4GB DIMMs) cannot be mixed with other memory DIMM sizes. When purchased from the factory, any given partition can be ordered with 4 GB DIMMs or non stacked DIMMs (512 MB, 1 GB or 2 GB), but not both. When field integrated, cell boards can contain 4 GB DIMMs or non stacked DIMMs (512 MB, 1 GB or 2 GB), but not both.

### HP 9000 rp8420 Server Memory DIMMs

Quad Size (product)	rp8420 Product Number	rp8400 Product Numbers that are supported	HP 9000 rp8420 Server Maximum Capacity Using 1 DIMM Size	DIMM Size
2 GB	AB307A	A6097A	32 GB	512 MB
4 GB	AB308A	A6098A	64 GB	1024 MB
8 GB	AB309A	A6100A	128 GB	2048 MB
16 GB	AB322A	-	256 GB	4096 MB

### Memory Loading Rules

- Memory must be installed in quads (4 DIMMs of equal density)
- Memory is available in four densities: 2 GB (4×512MB), 4 GB (4×1024MB), 8 GB (4×2048MB), and 16-GB (4 x 4096MB)
- Minimum memory is 2-GB per cell
- Maximum memory per system is 256 GB-using sixteen 16 GB Quads.
- On each cell board, Memory Quads must be installed in the following order: 1<sup>st</sup> (0A, 0B, 1A, 1B), 2<sup>nd</sup> (2A, 2B, 3A, 3B), 3<sup>rd</sup> (4A, 4B, 5A, 5B), 4<sup>th</sup> (6A, 6B, 7A, 7B)

### Performance Tuning Guidelines

- For best performance, a cell should be configured with a multiple of 8 DIMMs or two quads (although the server will execute properly with an odd number of quads. It takes 8 DIMMs to populate both buses. Populating only one of the two memory buses on a cell board will deliver only half the peak memory bandwidth.
- Load memory equally across the available cell boards.
- If growth is planned for the system, then plan on configuring high density 4, 8-GB, or 16-GB modules to minimize future memory slot constraints.

### Memory Latencies

There are two types of memory latencies within the HP 9000 rp8420 Server:

1. Memory latency **within** the cell refers to the case where an application either runs on a partition that consists of a single cell or uses cell local memory.
2. Memory latency **between** cell refers to the case where the partition consists of two or more cell and cell interleaved memory is used. For example, for an rp8420 Server with four cells in the partition, 25% of the addresses are to memory on the same cell as the requesting processor, and the other 75% of the addresses are to memory on the other three cells.

The HP 9000 rp8420 Server memory latency depends on the number of processor modules in the partition. Assuming that memory accesses are equally distributed across all cell boards and memory controllers within the partition, the average idle memory latency (load-to-use) is as shown below:

## Configuration

Number of processor modules	Average Memory Latency
4-dual core processor module	241 ns
8-dual core processor module	324 ns
16-dual core processor module	366 ns

### I/O Architecture

Components within the I/O subsystem are the I/O controllers, internal peripheral bay, and multifunction Core I/O. The figure below shows the basic block diagram of the I/O subsystem. The HP 9000 I/O architecture utilizes industry standard PCI buses in a unique design for maximum performance, scalability and reliability.

The HP 9000 rp8420 Server contains two master I/O controller chips located on the PCI-X backplane. Each I/O controller contains sixteen high-performance 12-bit wide links, which connect to sixteen slave I/O controller chips supporting the PCI-X card slots and core I/O. Two links, one from each master controller is routed through the crossbar backplane and is dedicated to core I/O. The remaining thirty links are divided among the sixteen I/O card slots. This one card per link architecture leads to greater I/O performance and higher availability. Each controller chip is also directly linked to a host cell board. This means that at least two cell boards, located in cell slots 0 and 1, must be purchased in order to access all sixteen I/O card slots. With one cell board, access to eight slots is enabled.

The HP 9000 rp8420 Server can be purchased with either one or two core I/O boards (If an SEU is added, then 4 core I/O boards with 2 Core I/O in the SEU). Both core I/O boards are identical and provides console, SCSI, serial, and Management Processor (MP) functionality. The second core is used to enable the dual partitioning in the HP 9000 rp8420 Server and provide access to a second set of disk drives.

The internal peripheral bay is divided into two identical halves. Each half supports up to two low-profile disks and one removable media device. A SCSI controller chip located on each core I/O board supports each half of the internal peripheral bay. This means that both core I/O boards must be purchased to access both halves of the peripheral bay.

### PCI-X Backplane

Fourteen of the sixteen I/O card slots are supported by dual high-performance links. Each link is capable of providing 530 MB/s of bandwidth. This means that most HP 9000 rp8420 Server I/O slots are capable of sustained 1.06 GB/s. Aggregate I/O slot bandwidth is 15.9 GB/s. In addition, because each I/O slot has a dedicated bus, any slot can be "hot-plugged" or serviced without affecting other slots. The hot-plug operation is very easy, and can be done with minimal training and effort.

The HP 9000 rp8420 Server supports a number of PCI and PCI-X HBA (I/O) cards for I/O expansion (see Table below). Note that the PCI-X backplane is backward compatible with the older PCI backplane and can support many PCI HBA (I/O) cards.

When HP 9000 rp8400 servers are upgraded to HP 9000 rp8420 servers using the chassis upgrade kit A9785A, the older and slower PCI backplanes in the HP 9000 rp8400 server are upgraded to the newer and faster PCI-X backplanes of the HP 9000 rp8420 Server.

When the rp84xx/px86xx Server Expansion Unit is connected to the HP 9000 rp8420 Server, its I/O backplanes act as PCI-X I/O backplanes. See the rp84xx/px86xx Server Expansion Unit section for more details.

### Supported I/O Cards (HBAs)

## Configuration

I/O Card	Product Number	First HP UX Release / Boot Support	Connector Type(s)	Hot Plug / Factory Integration	Max Cards / Max Ports
<b>Mass Storage Host Bus Adapters</b>					
PCI 1 port 2x Fibre Channel	A5158A	11.00 / No	Duplex SC	Yes / Yes	16 / 16
PCI 2-Gb Fibre Channel	A6795A	11.00 / Yes	LC	Yes / Yes	16 / 16
PCI 4-Gb Fibre Channel	AB387A	11i/Yes		Yes / Yes	16 / 16
PCI 1 channel U 160 SCSI	A6828A	11.00 / Yes	VHDCI	Yes / Yes	16 / 16
PCI 2 channel Ultra160 SCSI	A6829A	11.00 / Yes	VHDCI	Yes / Yes	16 / 32
PCI 2 channel Ultra320 SCSI	A7173A	11i / Yes	VHDCI	Yes / Yes	16 / 32
PCI-X 2 channel 2-Gb/s Fibre Channel	A6826A	11i / Yes	LC (SFF)	Yes / Yes	16 / 32
PCI 1 port Ultra2 SCSI	A5149A	11.00 / No	VHDCI	Yes / Yes	16 / 16
PCI 2 port Ultra2 SCSI	A5160A	11.00 / No	VHDCI	Yes / Yes	16 / 16
PCI-X 2 channel Ultra SCSI	A5150A	11.00 / No	VHDCI	Yes / Yes	16 / 32
PCI-X 2 port SmartArray 6402	A9890A	11i / Yes	VHDCI	Yes / Yes	16 / 32
PCI-X 2 port SmartArray 6404	A9891A <sup>1</sup>	11i / Yes	VHDCI	Yes / Yes	16 / 32
PCI-X 2 port SmartArray 5304	A7143A <sup>1</sup>	11i / Yes	VHDCI	Yes / Yes	16 / 32
<b>Local Area Network Interface Cards</b>					
PCI-X 1-port 10 Gb Ethernet Fiber Adapter	AB287A	11iv2 / No	Duplex LC	Yes / Yes	2 / 2
PCI-X 4-port 1000Base-T Gigabit Adpt	AB545A	11i v2	RJ-45	Yes / No	16 / 64
PCI-X 2 port 1000Base-SX	A7011A	11i / Yes	Duplex SC	Yes / Yes	16 / 32
PCI-X 2 port 1000Base-T	A7012A	11i / Yes	RJ-45	Yes / Yes	16 / 32
PCI 1 port 1000Base-SX	AD331A	11i/Yes	Duplex SC	Yes / Yes	16 / 16
PCI 1 port 1000Base-T	AD332A	11i/Yes	Duplex SC	Yes / Yes	16 / 16
PCI 1 port 1000Base-SX	A4926A	11.00 / No	Duplex SC	Yes / Yes	16 / 16
PCI 1 port 10/100Base-T	A5230A	11.00 / No	RJ-45	Yes / Yes	16 / 16
PCI 1 port 1000Base-T	A4929A	11.i / No	RJ-45	Yes / Yes	16 / 16
PCI 4 port 10/100Base-T	A5506B	11.00 / No	RJ-45	Yes / Yes	16 / 64
PCI 1 port 802.5 Token ring 4/16/100 Mb/s	A5783A	11.00 / No	RJ-45 and DB-9	Yes / Yes	16 / 16
PCI 1 port Universal FDDI	A3739B	11.00 / No	FDDI SC	Yes / Yes	16 / 16
PCI-X 2 port 4X Infiniband HCA (HPC)	AB286A	11iv2/Yes	4x Infiniband Copper	Yes/Yes	8/16
PCI-X 2 port 4X Fabric (HA and DB) Adapter <sup>2</sup>	AB345A	11iv2/No	4x Infiniband Copper	Yes/No	16/32
<b>Multi-Function Cards (Mass Storage &amp; LAN)</b>					
PCI 2 port 100Base T/ 2 port Ultra2 SCSI	A5838A	11.00 / Yes	VHDCI/RJ-45	Yes / Yes	16 / 64
PCI-X 2Gb Fibre Channel / 1000Base-SX	A9782A	11i / Yes	LC (SFF) / LC GigE	Yes / Yes	14 / 28
PCI-X 2Gb Fibre Channel / 1000Base-T	A9784A	11i / Yes	1 LC, 1 RJ-45	Yes / Yes	16 / 32
PCI-X 2-port 2Gb FC/ 2-port 1Gb Ethernet	AB465A	11iv2 / Yes	2 LC/2 RJ-45	Yes / Yes	16 / 64
PCI-X 2-port 1000BT/2-port U320 SCSI	AB290A	11i/Yes	2 LC GigE/2 RJ-45	Yes/Yes	16/64
<b>Wide Area Network Interface Cards</b>					

### Configuration

PCI 1-port ATM 165 Mb/s Multi-Mode Fiber (MMF)	A5513A	11.00 / No	Duplex SC	Yes / Yes	16 / 16
2 port Programmable Serial Interface (PSI) X.25 / Frame Relay / SDLC	J3525A	11.00 / No	RS-530, RS-232, V.35, RS-449 or X.21	Yes / Yes	16 / 32
<b>Additional Interface Cards</b>					
PCI 8-port Terminal Multiplexer	A6748A	11.00 / No	RS-232	Yes / Yes	16 / 128
PCI 64-port Terminal Multiplexer	A6749A	11.00 / No	RS-232 or RS-422	Yes / Yes	16 / 1024
PCI Hyperfabric2 Fiber Adapter	A6386A	11.00 / No	LC Duplex	Yes / Yes	4 / 4

<sup>1</sup>I/O card NOT supported in SEU. <sup>2</sup>I/O card will be formally supported late in CY2005

### Integrated Multifunction I/O

The HP 9000 rp8420 Server chassis supports either one or two Core I/O cards (AB306A). Core I/O slots are located along the right rear vertical edge of the chassis. A minimum of one core I/O card must be ordered with each system. For support of 3 or 4 hard partitions (nPars), a third and/or fourth core I/O card can be added in the rp84xx/rx86xx Server Expansion Unit. See its section for more details.

When upgrading HP Server rp8400s ordered before September 2003, these older servers will require a Core I/O board upgrade. These servers were ordered with Core I/O product A6096A, which is not supported in the rp8400 to rp8420 Server upgrade. HP Server rp8400s ordered after September 2003 were delivered with Core I/O product A7109A, which is supported in the rp8400 to rp8420 Server upgrade.

Each HP 9000 core I/O card provides the following features:

- **Management Processor:** The Management Processor (MP) is a dedicated processor that simplifies and extends system management, as well as, enhances serviceability. The MP feature set was designed to minimize/eliminate the need for the System Administrator to be physically at the system to perform tasks such as diagnostics, system management, or even hard resets.
  - Features:
    - System management over the Internet or Intranet
    - System console redirection
    - Console mirroring
    - System configuration for automatic restart
    - Viewing history log of system events
    - Viewing history log of console activity
    - Setting MP inactivity timeout thresholds
    - Remote system control
    - Remote power cycle (except for MP housekeeping power)
    - Viewing system status
    - Event notification to system console, e-mail, pager, and/or HP Response Centers
    - Automatic hardware protection of critical environmental problems
    - Access to management interface and console(s) on LAN failure (modem required)
    - Auto system restart
    - Remote resetting of hardware partitions
    - Forward progress indicator (Virtual front-panel)
    - Out-of-band Manageability and PDC firmware update
    - Configure manageability and console security
    - SSL (Secure Sockets Layer)
- **External LAN port:** 10/100/1000Base-T LAN port using an RJ-45 connector
- **External SCSI port:** Ultra3 LVD SCSI port for connections to mass storage or media

### Configuration

- **Access to internal peripheral bay:** The first core I/O card enables half of the HP 9000 rp8420 Server peripheral bay, which includes one removable media and two low profile disks. The second core I/O card enables the remaining internal peripherals, two disks and one removable media bays. Customers that require access to more than two internal disks and/or one removable media slot must purchase the second core I/O card and more than one cell board.

The integrated multifunction I/O provides core I/O functionally and includes the Management Processor technology.

#### Core I/O Loading Rules

- Minimum of 1 Core I/O board must be purchased with each HP 9000 rp8420 Server
- Load the 1st Core I/O board into slot 0.
- Core I/O slot 0 corresponds to Cell Board slot 0. Core I/O slot 1 corresponds to Cell Board slot 1.
- A cell board must be installed in slot 0 to enable use of Core I/O 0. Likewise, a cell board must be installed in slot 1 to enable use of Core I/O 1.
- Access to two internal disk drives and 1 Removable Media bay is enabled with the installation of the 1st Core I/O board.
- The optional second Core I/O board must be ordered to enable hardware partitioning (systems not using the Server Expansion Unit).

The optional second Core I/O board must be ordered to enable access to the 3rd/4th internal disks and 2nd removable media drive.

**(NOTE: For support of 3 or 4 hard partitions (nPartitions), a third and/or fourth core I/O board can be added in the rp84xx/rx86xx Server Expansion Unit. See its section for more details.)**

#### Internal Disk Drives

- HP 9000 rp8420 Server chassis supports up to four internal low-profile hot-plug disk drives in three capacities.
- Two UltraSCSI controllers provide each disk drive with an independent SCSI channel
- Supported by MirrorDisk/UX across disk drives, controllers, and Core I/O boards
- Must order two Core I/O cards to support more than two internal disk drives

#### Internal Disk Drive Specifications

Product Number	rp8400 Product Numbers that are supported	Disk Capacity	Rotational speed	Average seek time (read/write)	Sustained Bandwidth
A9880A	A6831A	36 GB	15,000 RPM	3.6 msec (read); 3.9 msec (write)	75 MB/s
A9881A	A6725A	73 GB	15,000 RPM (A9881A) 10,000 RPM (A6725A)	3.6 msec (read); 3.9 msec (write) (A9881A) 4.7 msec (read); 5.2 msec (write) (A6725A)	75 MB/s (A9881A) 69 MB/s (A6725A)
A9882A	A7083A	146 GB	10,000 RPM	4.7 msec (read); 5.2 msec (write)	69 MB/s
AD050A	N/A	300 GB	10,000 RPM	4.7 msec (read); 5.2 msec (write)	69 MB/s
AD146A	N/A	36 GB	15,000 RPM	3.6 msec (read); 3.9 msec (write)	75 MB/s
AD209A	N/A	73 GB	10,000 RPM	4.7 msec (read); 5.2 msec (write)	69 MB/s
AD148A	N/A	146 GB	10,000 RPM	4.7 msec (read); 5.2 msec (write)	69 MB/s

### Configuration

AD149A	N/A	300 GB	10,000 RPM	4.7 msec (read); 5.2 msec (write)	69 MB/s
--------	-----	--------	------------	-----------------------------------	---------

#### Internal Removable Media

- HP 9000 rp8420 Server contains two removable media bays, which will support either a DVD-ROM or DDS-4 DAT drive. Removable media drives are not hot-plug capable.
- DVD-ROM drive provides enhanced features while preserving backward read compatibility with CD-ROM. Data transfer rates of up to 6.75 MB/s are achieved with the DVD format; 4.8 MB/s can be achieved with the CD format.
- DDS-4 drive has a maximum storage capacity of 40 GB with a peak transfer rate of 21.6 GB/hour compressed.
- Must order two Core I/O cards to enable more than one Internal Media device.

#### Internal Removable Media Specifications

Product Number	rp8400 Product Numbers that are supported	Device	Capacity	Data transfer rate
A9879A	A6180A	DVD-ROM drive	650 MB	6.75 MB/s
A9878A	A6182A	DDS-4 tape drive	40 GB	21.6 GB/hour
AB351A*	N/A	DVD+RW drive		
AB351B*	N/A	DVD+RW		
AB400A	N/A	DAT	72 GB	

\*NOTE: Third Party software (not included with AB351A & B) is required to support DVD write capability with Windows.

**I/O Configuration Rules** The following table summarizes previously mentioned configuration rules pertaining to usage of I/O slots and internal peripherals within the HP 9000 rp8420 Server chassis.

Configuration	Minimum Number of Cells	Minimum Number of Core I/Os
>8 I/O card slots	2	1
>2 Internal Disks	2	2
2 Internal Removable Media	2	2
2 Partitions	2	2

#### Addition I/O resources using the Server Expansion Unit (SEU)

Additional I/O resources can be obtained by adding the HP Server Expansion Unit (SEU). The SEU is an add on chassis containing I/O resources that complement the I/O and partitioning capabilities within the HP 9000 rp8420 Server. The SEU mirrors the I/O resources embedded within the HP 9000 rp8420 Server chassis, adding 16 PCI X I/O card slots, 4 disk bays, 2 removable media slots, and enabling 2 additional hard partitions in the server.

The SEU must be installed in the same cabinet and directly above the host HP 9000 rp8420 Server for factory racked installations. For field installations, the SEU can be installed in an adjacent rack at the same height as the server if there is space limitations. The preferred installation is directly above the host server in the same rack . Please refer to therp84xx/rx86xx Server Expansion Unit section in this guide for more specific details.

The following table summarizes the I/O configuration rules when an SEU is configured with the HP 9000 rp8420 Server.

## Configuration

Required Configuration	Minimum Required Number of Cells	Minimum Required Number of Core I/Os
>16 I/O card slots	3	4 <sup>1</sup>
>24 I/O card slots	4	4 <sup>1</sup>
>4 Disks	3	4 <sup>1</sup>
>6 Disks	4	4 <sup>1</sup>
3 Removable Media	3	4 <sup>1</sup>
4 Removable Media	4	4 <sup>1</sup>
3 Hard Partitions	3	4 <sup>1</sup>
4 Hard Partitions	4	4 <sup>1</sup>

**NOTE 1:** Two Core I/O cards must be purchased and configured in the SEU.

### AC/DC Power

#### DC Power Supplies

The HP 9000 rp8420 Server supports up to six hot-swap bulk power supplies for 2N+1 protection. The hot-swap design allows for the replacement of a failed power supply without interrupting server operation. Two supplies are included with the base system. A minimum of one additional supply is required for each cell board. Following this rule, all configurations will have 2N+1 power protection.

**PCI Power Supplies:** Each PCI power supply is dedicated to a single I/O bay. A PCI power supply failure will affect the hard partition or nPar utilizing that PCI supply and the associated I/O bay. All other nPars will continue normal operation. For high availability, consider mirroring two nPars using MC/Serviceguard. PCI power supplies are not hot-swap capable.

#### AC Power

The HP 9000 rp8420 Server contains four C20 power receptacle ports located at the bottom rear bulkhead. A minimum of two power cords must be used to maintain normal operation of the HP 9000 rp8420 Server. A second set of two cords can be used to improve system availability by protecting, for example, against power grid failures or accidentally tripped circuit breakers. The HP 9000 rp8420 Server hardware is capable of receiving AC input from two different AC power sources. The objective is to maintain full equipment functionality when operating from power source A and power source B, or A alone, or B alone. This capability is called "fault tolerant power compliance".

Although many HP 9000 rp8420 Server configurations can be sufficiently powered from a single 16 /20 amp branch circuit, HP strongly recommends using one 16 amp (minimum) branch circuit per power cord. Due to the variety of 16/20 plugs used throughout the world, the HP 9000 rp8420 Server menu offers a choice of plug options.

All HP 9000 rp8400 servers are shipped with four AC power cords.

### Configuration

**AC Power Consumption** The HP 9000 rp8420 Server power consumption will vary greatly depending on the hardware configuration and the input line voltages supplied at customer sites. Because of the disparity of line voltages throughout the world it's best to represent power consumption in VA (Volt\*Amperes). With power consumption being of high concern throughout the world, it's necessary to specify consumption in a couple of different ways.

**Maximum Theoretical Power:** or "Maximum Configuration" (Input power at the ac input expressed as Volt-Amps to take into account Power factor correction.)

The calculated sum of the maximum worst case power consumption for every subsystem in the server. This number will NEVER be exceeded by a functioning server for any combination of hardware and software under any conditions.

**Marked Electrical Power:** (Input power at the ac input expressed as Volt-Amps.)

The server Marked Electrical Power is the rating given on the chassis label and represents the input power required for facility ac power planning and wiring requirements. This number represents the expected maximum power consumption for the server based on the power rating of the bulk power supplies. This number can safely be used to size ac circuits and breakers for the system under all conditions.

**Typical Maximum Power:** or User Expected Maximum Power, "Typical Configuration" (Expressed as Volt-Amps.)

The measured maximum worst case power consumption. This number represents the largest power consumption that HP engineers were able to produce for the server with any combination of hardware under laboratory conditions using aggressive software applications designed specifically to work the system at maximum load. This number can safely be used to compute thermal loads and power consumption for the system under all conditions.

#### HP 9000 rp8420 Server Fully Loaded Configuration:

- Sixteen dual core 1.1 GHz PA 8900 processor modules
- 256 GB of memory
- 16 PCI cards
- 4 cell boards
- 4 internal hard drives
- 2 DVD drives
- 2 Core I/O boards
- 6 bulk power supplies.
- Typical Maximum power: 3560 VA (3489 W) (17.8 A @ 200 VAC across 2 cords)
- Theoretical Maximum power: 5100 VA (4998 W) (25.5 A @ 200 VAC across 2 cords)
- Marked Electrical power: 5,400 VA, 30A @180VAC

#### HP 9000 rp8420 Server Average Configuration:

- Eight 1.1 GHz dual core PA 8900 processor modules
- 16 GB of Memory
- 8 PCI cards
- 2 cell boards
- 2 internal hard drives
- 0 DVD drives
- 2 Core I/O boards
- 4 bulk power supplies.
- Typical power consumption: 1809 VA (9.1 A @ 200 VAC across 2 cords)

### Configuration

**Power Distribution Units**    **60 amp Power Distribution Unit-**  
AF916A (NA/JPN) and AF917A (international) - supported with 10K G2 rack  
E7683A (NA/JPN) and E7684A (International) - supported with Rack System E

A 60 amp Power Distribution Unit (PDU) has been developed for HP 9000 customers that prefer to use fewer, higher amperage connections into their wall electrical infrastructure. This PDU is sold separately and can be ordered with any HP Server solution. For more details on PDU's, please refer to the PDU sales collateral.

**Example of how the PDU can be configured with the HP 9000 rp8420 Server in a dual grid configuration:** In this case there are two HP 9000 rp8420 servers (average configurations drawing ~9 amps each) and two 60 amp PDUs configured with redundant power. The blue cords represent the primary power connections needed for normal operation. In this example, cords from each server are plugged into a separate branch circuits. However, it is acceptable, for lower VA configurations, for each server to plug both grid A cords into one branch circuit and both grid B cords into 2nd branch circuit. The remaining PDU outlets can be used to power other components as long as the specs per PDU rating is not exceeded.

For redundant power inputs, the second set of red cords is added. If the second PDU is plugged into a second grid this configuration provides protection against:

- Losing power from a single power grid
- Accidental tripping of one or two circuit breakers
- Accidental disconnect of a single PDU power cord
- Accidental disconnect of up to four system power cords

**30 amp Power Distribution Unit-**  
252663-D74 (NA/JPN) and 252663-B33 (international) - supported on 10KG2 rack  
E7681A (NA/JPN) and E7682A (International) - supported on Rack System E

A 30 amp Power Distribution Unit (PDU) is also supported with HP 9000 rp8420 Server. This PDU is sold separately and can be ordered with any HP Server solution.

Unlike the 60 amp PDU, each 30 amp PDU can only support one HP 9000 rp8420 Server. The following configuration guidelines apply when using the 30 amp PDU:

- HP 9000 rp8420 Server plugs A0 and A1 should be plugged into the same PDU
- Ax and Bx cords should never be plugged into the same PDU
- Use two 30 amp PDUs to achieve input power redundancy. A0/A1 and B0/B1 into separate PDUs.
- Ordering tools will not force the purchase of a second PDU for input power redundancy. A second PDU must be manually selected if redundant input power is desired.

## Configuration

### Partitioning

A hardware partition corresponds roughly to a single, standalone system. The HP 9000 rp8420 Server can be subdivided into four partitions, each containing one or more cells that communicate coherently over a high bandwidth, low latency crossbar fabric. Cells are grouped into physical structures called cabinets or nodes. Special programmable hardware in the cells defines the boundaries of a partition in such a way that the isolation is enforced from the actions of other partitions. Each partition runs its own independent instance of the operating system. Applications cannot span partitions since each partition runs its own instance of the OS, essentially functioning as a stand-alone server. However, different partitions may be executing the same or different revisions of an operating system.

Each partition has its own independent processor modules, memory and I/O resources consisting of the resources of the cells that make up the partition. Resources may be removed from one partition and added to another without having to physically manipulate the hardware just by using commands that are part of the System Management interface. With a future release of HP-UX, using the related capabilities of dynamic reconfiguration (e.g. on-line addition, on-line removal), new resources may be added to a partition and failed modules may be removed and replaced while the partition continues in operation. Partitioning the resources of the complex in this way makes it easy to run multiple applications on the same physical system; you can allocate physical resources and tune the operating system running on each partition depending on the needs of the application (or the most important application) you intend to run on it. Alternatively, you can configure the HP 9000 rp8420 Server as a single partition, allowing all the resources to be focused on a single set of tasks, for example a large online transaction-processing application.

You can increase or reduce the processing power of a partition by adding or deleting cells (with the current HP-UX release, you must shut down the operating system running on the affected partition(s) before moving cells, and before configuration changes will take effect). Though HP-UX 11i does include commands for some configuration tasks, HP recommends you use the Partition Manager (parmgr) to configure partitions.

The current release of HP 9000 rp8420 Server/HP-UX 11i supports hardware partitioning. Hardware based partition configuration changes may require a reboot of the partition depending upon the configuration change. The reboot of the partition only affects the partition that is being reconfigured. The other partition defined in the chassis is not affected and will continue to execute without interruption. In a future HP-UX release, dynamic hard partitions will be supported. Dynamic partitions imply that partition configuration changes do not require a reboot of the partition.

The HP 9000 rp8420 Server can be divided into four independent hardware partitions when configured with the rp84xx/rx86xx Server Expansion Unit. In a partitioned configuration, I/O bay resources such as I/O slots, core I/O, disk and removable media bays, are always dedicated to the corresponding cell board slot. In other words, I/O bay 0 resources are always configured to the cell board in Cell slot 0. Therefore, in a partitioned system, the amount of resources within a partition is always proportional to the number of cells within that partition. There is no flexibility to otherwise divide these components. For example, in a system configured with two cells in separate nPars, it is not possible to include twelve I/O slots in partition 0 and four I/O slots in partition 1. Please refer to the "HP Server Expansion Unit" section in this guide or more specific details.

The table below summarizes the resource availability based on hardware partitions.

Number of Hard Partitions	Minimum # of Cells	Available I/O slots (min)	Core I/O (required)	Available Disk/Media Bays (min)
1 Partition	Any one Cell	8	1	2/1
2 Partitions	Any two Cells	16	2	4/2
3 Partitions	Any three Cells	24	4	6/3
4 Partitions	Four Cells	32	4	8/4

### Configuration

In addition to hard partitioning (nPars), HP 9000 rp8420 servers support virtual partitioning (vPars) to the single processor or processor level (expected release of support or vPars on HP 9000 rp8420 servers in second calendar quarter of 2004). With vPars, a user may support up to eight separate virtual partitions each with an instance of HP-UX 11i v1 within each hard partition. VPars provides many of the features of nPars but without the electrical isolation and support for hardware failures that nPars provides.

**Instant Capacity** (iCAP) (formerly known as Instant Capacity on Demand [iCOD]).

### Racking

The HP 9000 rp8420 Server was designed to provide industry leading performance density and availability when ordered in a racked configuration. At 17 EIA units (29.75 inches), two HP 9000 rp8420 servers or one rp8420 with a Server Expansion Unit can be mounted into a single HP two meter cabinet with 7 EIA units of extra space for mounting external peripherals.

The HP 9000 rp8420 Server industrial design and packaging was designed to allow easy and quick access to all of the system's components. The most frequently handled devices, removable media and disks, are directly accessible at the system's front. By removing the front bezel, hot swap fans, hot swap power supplies, and PCI power supplies can be completely serviced. At the rear, core I/O and more hot swap fans are directly accessible. For access to all other components, the rack mounted HP 9000 rp8420 Server comes with rack sliders. These rack sliders enables the HP 9000 rp8420 Server to be slid forward out of the HP cabinet for servicing of internal components such as fans, cell boards, and I/O cards, while the system is still running. The sliders also allows for servicing or replacement of any FRU (field replaceable unit) without removing the chassis from the cabinet. The HP 9000 rp8420 Server industrial design and slider strategy enables access and removal of any FRU within 15 minutes or less. This design feature minimizes the downtime associated with system upgrades in the rare event of a component failure. Also included with ever rack mounted HP 9000 rp8420 Server is a cable management arm (CMA) The CMA neatly secures data cables and prevents cables from becoming entangled while servicing of the system.

The following racking rules apply for HP 9000 rp8420 servers configured with an HP Server Expansion Unit.

- The HP Server Expansion Unit must be mounted in the same cabinet as the host HP 9000 rp8420 Server
- The HP 9000 rp8420 Server must be mounted directly below the HP Server Expansion Unit

### Ballasts for HP Rack System E cabinets (not required for new Universal 10K G2 rack)

Due to the weight of the HP 9000 rp8420 Server, ballast kits have been developed to add stability to HP cabinets while the system is being serviced. Every HP 9000 rp8420 Server shipped to customers, excluding Pedestal models, will be shipped with a ballast kit. These ballasts were designed to easily attach to the rear anti tip foot that comes standard with every HP Rack System E cabinet. Use of the HP 9000 rp8420 Server ballast kit is mandatory and should be installed immediately.

### Heavy Duty Stabilizing Kit for 10K G2 racks (not for HP System E racks)

A heavy duty stabilizing kit is required for the rack of the rx8640 server to add stability for the HP Universal 10K G2 rack. With this stabilizing kit, the ballast is no longer needed with the new HP Universal rack. Use of the Heavy Duty Stabilizing kit is mandatory and should be installed immediately.

Refer to the 10000 G2 Series Rack Best Practices Guide for information on rack deployment, stabilization and transportation. Go to <http://www.hp.com/go/rackandpower> for more information.

## Configuration

### Third-Party Racking

HP Servers are designed to maximize performance density when installed into HP system cabinets. HP system cabinets maintain the high level of safety and reliability of HP Server solutions that customers have come to expect. Although HP strongly recommends racking servers in HP cabinets, it recognizes that some customer circumstances may prohibit this. For those customers, HP has developed a set of guidelines that when followed, enables server installations into third-party cabinets. It is extremely important that the guidelines be followed due to the wide variety of cabinets in the market place.

When field racking for the mid-range servers in any rack (10K G2, System E or 3rd party), the customer will have to order the appropriate service product (HP PN: HA124A1 Opt. 570 - HP Startup Field Racked Mid Server Service).

### Upgrades

#### HP 9000 rp8420 Upgrades to HP Integrity rx8620 Servers

The HP 9000 rp8420 Servers were designed to be easily upgradeable to Intel Itanium 2 and PA RISC processors. With the release of the Intel Itanium 2 and the HP mx2 processors, HP 9000 rp8420 Server customers can now upgrade their systems as desired. Here are the components that a customer will need to order to do a board level upgrade to these new servers from an rp8420:

- **A chassis upgrade kit:** This product will contain a new server name insert for the front bezel, new firmware and various labels to apply to the server.
  - HP 9000 rp8420 to HP Integrity rx8620 upgrades-use product A9787A
- **No new cell boards and memory:** Cell boards are the same between PA-8900/8800 servers and Intel Madison 2 and HP mx2-based servers.
  - When upgrading to mx2 modules and if ordering 1 processor module per cell board, you must order cell board processor terminator (AB225A)
  - When upgrading to HP mx2 modules, you must buy one cell board baffle (A9792A) per cell board being upgraded
- **New processor modules:** HP sells two processors per module. These will replace two processors of the older modules.
  - Intel Itanium 2 dual-core module, 1.3-GHz, 3-MB cache-use product A9765A
  - Intel Itanium 2 dual-core module, 1.5-GHz, 6-MB cache-use product A6438A
  - HP mx2 dual-processor module, 1.1-GHz, 4-MB L3 cache, 32-MB L4 cache-use product A9767A
- **Return credits:** If the customer returns his old processor modules, they can get a return credit. **(NOTE: These are single processor credits, not dual-core module credits. This means that two PA-8900/PA-8800 return credits should be ordered for each new dual-core module purchased.):**
  - rp8420 900-MHz single processor return credit-use product A6436AN option 001
  - rp8420 1-GHz single processor return credit-use product A6437AN option 001
- **Software:**
  - For the HP Integrity servers, the operating system needs to be upgraded to HP-UX 11i version 2.

## Technical Specifications

Server model number    rp8420

---

Server product numbers    Base                            A6912A  
                                  Number of processors    1 (32)  
                                  (number of cores)

---

Supported Processors    PA-8900 Dual core 1.1    L1 Cache (1.5-MB/core)    3 MB  
                                  GHz Processors            L2 Cache                    64 MB  
                                  PA-8900 Dual core 1.0    L1 Cache (1.5-MB/core)    3 MB  
                                  GHz Processors            L2 Cache                    64 MB  
                                  PA-8800 Dual core 1.0    L1 Cache (1.5-MB/core)    3 MB  
                                  GHz Processors            L2 Cache                    32 MB  
                                  (Obsoleted)  
                                  PA-8800 Dual core 900    L1 Cache (1.5-MB/core)    3 MB  
                                  MHz Processors            L2 Cache                    32 MB  
                                  (Obsoleted)

---

Memory                    Memory slots                64 (16 per cell board)  
                                  Minimum memory (Quad    2 GB  
                                  4 DIMMs)  
                                  Maximum memory            256 GB (64 GB per cell board)  
                                  capacity

---

Internal Disks            Maximum disk                4  
                                  mechanisms  
                                  Maximum disk capacity    1.2 TB  
                                  Internal Removable        2 slots  
                                  Media  
                                  DVD+RW  
                                  DDS 4 DAT (optional)      40 GB

---

Internal Removable    2 slots  
Media                    DVD+RW  
                                  DDS 4 DAT (optional)      40-GB

---

## Technical Specifications

Core I/O	Ultra3 SCSI-LVD	Yes
	10/100/1000Base-T (RJ-45 connector)	Yes
	RS-232 serial ports (one console and one UPS)	2
	10/100Base-T port (Web and LAN console conn.)	Yes

I/O Buses and Slots	Total Hot-plug PCI-X Slots	16
	(133 MHz×64 bits)	
	14 Dual channel slots (1060 MB/s each)	
	2 Single channel (530 MB/s each)	

Maximum I/O Cards See supported I/O table for specific products	Mass Storage	16
	LAN	8-16
	WAN	16
	Multi-Function (Mass Storage / LAN)	14-16
	Additional Interface Cards	4-16

Electrical Characteristics	AC Input power	200-240V 50/60 Hz
	Hotswap Power supplies	6 total, 2 included with base
	Redundant AC power inputs	2 required, 4 cords for 2N inputs
	Typical maximum power dissipation for maximum processor, memory, disk, I/O configurations	3560 VA (3489 W) 17.8A@ 200 VAC
	Marked Electrical for Server	5400 VA, 30A @180VAC
	Marked Electrical per line cord	2700 VA (15A @ 180VAC)
	Power factor at full load	0.98 (approximately)
	kW rating for UPS loading*	6.0

\*NOTE: Represents theoretical maximum power/heat dissipation under worst case conditions, may increase with future upgrades.

## Technical Specifications

<b>Site Preparation</b>	<b>Site planning and installation included</b>	Yes
	<b>Depth (in/mm)</b>	30 in (762 mm)
	<b>Width (in/mm)</b>	19 in (482 mm)
	<b>Height (in/mm/EIA) Racked</b>	29.75 in (755 mm)/17 units
	<b>Height (in/mm) Pedestal</b>	32.8 in (833 mm)
	<b>Weight (lb/kg)</b>	171.4 kg (378 lbs)

<b>Environmental Characteristics</b>	<b>Acoustics (sound power) at 25°C</b>	7.2 Bels LwA
	<b>Acoustics (sound power) at 30°C</b>	7.5 Bels LwA
	<b>Acoustics (operator/bystander) at 24°C</b>	61.0 dB LpA
	<b>Operating Temperature (up to 5000 ft)<sup>2</sup></b>	41° to 95° F (5° to 35° C)
	<b>Non-operating Temperature</b>	-40° to 158° F (-40° to 70° C)
	<b>Maximum rate of temperature change</b>	20° C/hour
	<b>Operating relative humidity</b>	15% to 80%, non-condensing, max. web bulb = 26° C
	<b>Non-operating relative humidity</b>	5% to 90%, non-condensing
	<b>Operating altitude above sea level</b>	To 3.0 km (10,000 feet)
<b>Non-operating altitude above sea level</b>	To 4.5 km (15,000 feet)	

**NOTE 2:** Maximum operating temperature range up to 1.524 km (5000) ft. For higher altitudes derate the max temperature by 1° C/350meters (1000 ft) above 1.524 km (5000 ft).

<b>Regulatory Compliance</b>	<b>Regulatory Model Number</b>	RSVLA-0102
	<b>Electromagnetic Interference</b>	Complies with FCC Rules and Regulations, Part 15, as a Class A digital device. Manufacturer's Declaration to EN55022 Level A, VCCI Registered, Class 1, Korea RLL
	<b>Safety</b>	UL Listed, cUL Certified, compliant with EN 60950

## *Technical Specifications*

© Copyright 2007 Hewlett-Packard Development Company, L.P.

The information contained herein is subject to change without notice.

Intel and Itanium are registered trademarks or trademarks of Intel Corporation in the U.S. and/or other countries.

The only warranties for HP products and services are set forth in the express warranty statements accompanying such products and services. Nothing herein should be construed as constituting an additional warranty. HP shall not be liable for technical or editorial errors or omissions contained herein.